TOP ONE TECH LIMITED
(The Water-proof,PCAP ,LED backlight)

23.8" LCD Open frame Touch Monitor

Model: TOT238UCA001

Part number:TOT238K1C001



Top One Tech's 23.8" open frame touch monitors have a long-lasting product cycle because the enclosure is controlled by Top One Tech's specifications. Future panel improvements are therefore possible without external changes. The TOT238UCA001 integrate with the Top One Tech's PCAP technology touchscreen.

Features

- Patented IP65 Front with silicon seal
- Long lasting product cycle-enclosure controlled by Top One Tech specifications
- Future generation panels phased-in without external changes
- High quality panel with high brightness , high contrast ratio and broad viewing angle
- Anti-glare treatment (chemical etching)
- Strengthened cover glass
- 10-finger-multi touch capacitive touch
- LED backlight backed Panels in A+ quality
- Screwable connection for rugged environments

Specification

Product name	23.8" PCAP Touch Monitor	
Modle numer	TOT238UCA001	
IP rated front panel	IP65	
Screen diagonal (Inch/mm):	23.8/546.9	
Display active screen size:	528×297.5 (mm)	
Aspect ratio:	16:9	
Physical resolution:	1920×1080	
Colours displayed:	16.7M	
Brightness (cd/m ²):	250cd/m ²	
Contrast:	3000:1	
Typical reaction time Tr/Tf :	12 (Typ.)/(G to G) 5ms	
Viewing Angle (Typ.at CR > 10)	Horizontal(left/right)	89°/89°
	Vertical(up/down)	89°/89°
Backlight / Backlight lifetime	LED / 40,000h	
Lifetime (hours):	≥30000h	
Touch Technology	Projected Capacitive 10-point Multitouch	
Touch Connector	USB	
Touch Panel Drivers	Windows; Linux; Android	
Touch Life (Contacts)	Unlimited	
Surface Hardness	6H	

Operating Temperature	0 ~ +50(°C)	
Humidity Range (RH)	20%-80%	
Net weight (kg)	10	
Gross weight (kg)	13 (incl. cartonage)	
Housing material	Metal	
Housing (cm) LxWxH	579.6*351.6*44.2	
Mounting	VESA 100/ VESA 75	
External Connectors	Video	1x VGA 1x DVI -D
	Audio	1x PC-Audio 1x Earphone-Out
	Touch Connector	1x USB
	Connectors	1x 12V DC-IN
	Power Indicator	Green LED
Power	Power Supply	100-240V ACDC active switch- ing; 12V DC-Out
	Working Power	12
	Power Consumption (W)	28
	Stand-By Consumption (W)	<1

NOTE:The display SPEC. will change follow the relevant LCD panel brand and model

Mechanical Dimensions

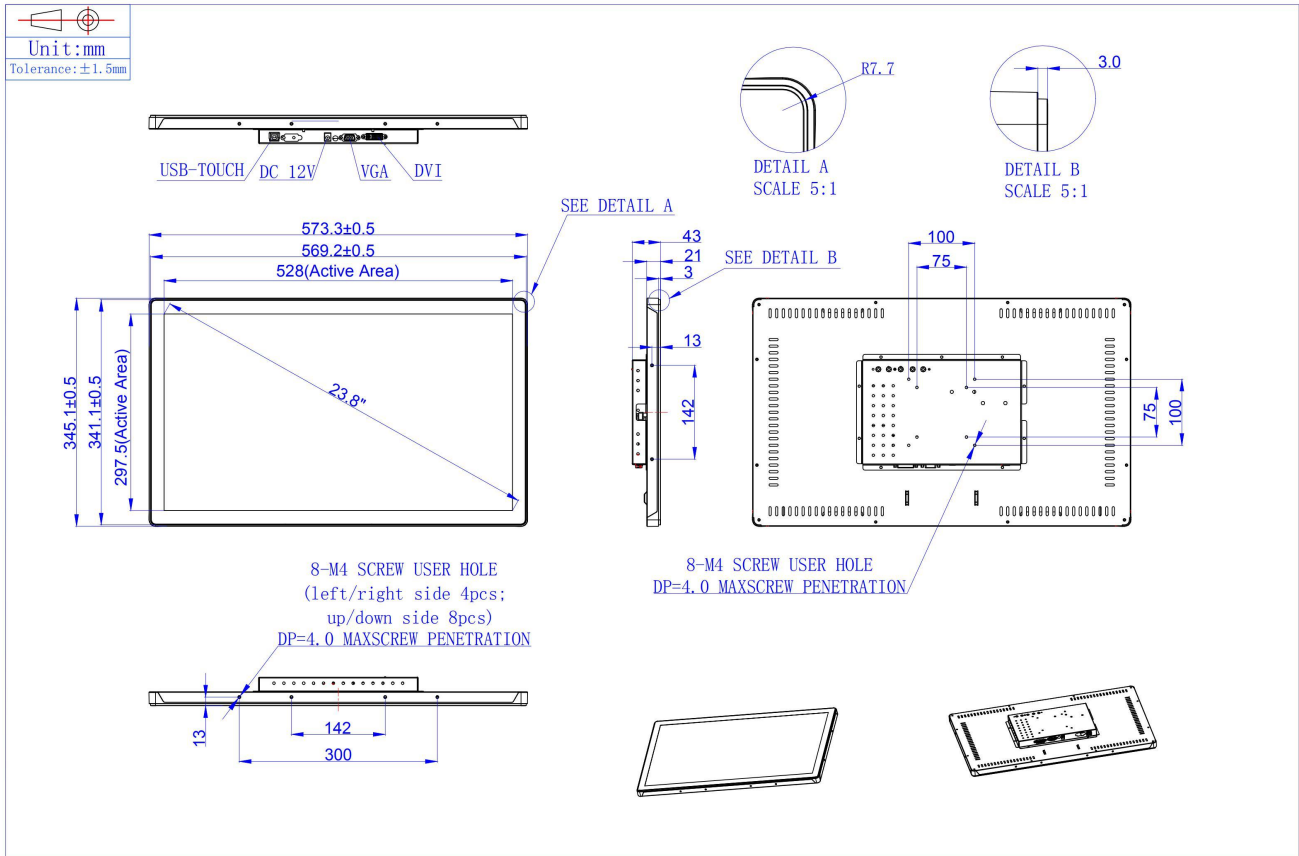

Accessories

Power Cable: A North American power cable or an European power cable is included according to the end user's area.

Power Supply Brick: A power supply brick is included.

Touch/Video/DVI Cables: Detachable serial or USB touch cable , video cable and DVI cable are included

L-brackets: Four standard L-brackets are included(optional by different size).

Typical Application

Gaming/Casino
Systems Outdoor and

indoor Kiosks
Entertainment
Transport and
Ticketing Hospitality
Banking
Customized Solutions

How to contact us

TOP ONE TECH LIMITED

Mobile Phone : (+86)13631610695

Tel: 0086-0755-21070641

Whatsapp/Wechat :+8613631610695

Email : sales@toponetech.cn

Skype : elsieyu-sz@hotmail.com

Office in China : Room 512 & 517, Taiyangneng Guigu Building Zhongxing Xiaoqu, Yunfeng Road
No.3 Gaofeng shequ, Longhua District, Shenzhen, China

Facilities in China : No. 2, Guihua Jiayi Industrial district, Guanlan, Longhua, Shenzhen, China 51804